

BM 51 B

TYPE	WEIGHT RANGE	CAPACITY
BM 51 B	110 - 1600 gr	up to 2000 pcs/h. depending on dough weight

DIMENSIONS		WEIGHT	CONNECTED LOAD
Lenght	2749 mm	nett 610 kg	230/400 V, 50 Hz + earth
Width	760 mm	gross...700.kg	0,55 kVA
Height	1800 mm	Shipping volume 3,9 m ³	

OPTIONS

- Infeed conveyor with centering rollers instead hopper (L=+352 mm)
- Driven opposite running curling chain
- Cutting station 2- or 4-pieces
- A-version (short version) L=2249 mm
- Extended version (L-version) with 2 moulding stations (pressure boards) L=3582 mm
- Customer specific Blue Box

WP HATON BV

Industrieterrein 13 // 5981 NK Panningen // Netherlands // Phone +31 77307-1860 // Fax +31 77307-5148 // info@wp-haton.com // www.wp-haton.com



BM 51 B

Long Moulder

BM 51 B

Picture BM 51 B with infeed conveyor

SUITABLE FOR WHEAT, WHEAT/RYE
(UP TO 30% RYE) DOUGHS.



BENEFITS

- Perfect sheeting results by drum principle
- Possibility to process many types of dough
- Modern design in stainless steel
- Easy to operate and maintain
- Adjustable folding blades during sheeting for short and long loaves
- Second roller spring loaded
- Blower on transfer drum
- Easy adjustable settings with read out
- Quick lock system on pressure board
- Double pressure board (option) for longer dwell time
- V underneath pressure board

BASIC EXECUTION:

- Infeed hopper with adjustable side walls
- Cover plates stainless steel
- Moulding bridge glass pearl blasted
- Adjustable synthetic rollers with synthetic scrapers, width 320 mm
- Sheeting head steel drum covered with synthetic sleeve
- 1st roller pair 3-40 mm, 2nd roller pair 3-40 mm
- Blower on transfer drum
- Stainless steel curling net
- Hinged pressure board, adjustable in height with adjustable Teflon coated side guides

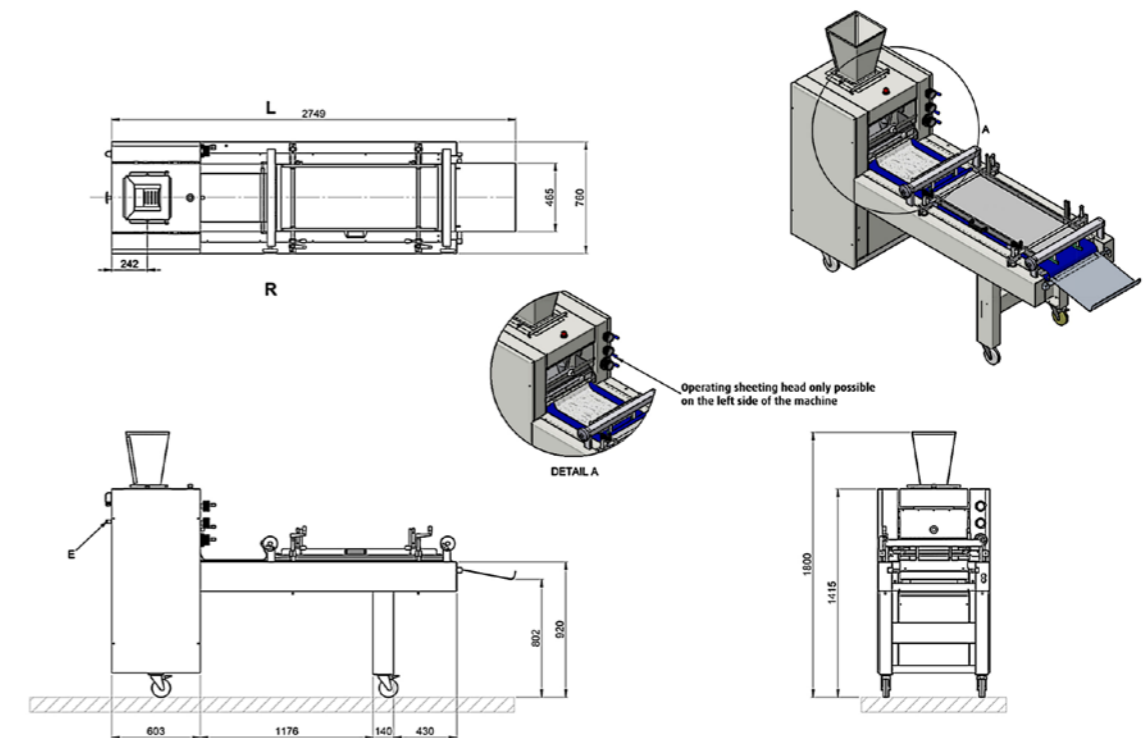

Illustration BM 51 B version