

COMBI E

TYPE	WEIGHT RANGE	CAPACITY
Combi E program:	200 - 2000 gr	max. 1500 pcs/h.
Combi E with sheeter head		depending on dough weight
Combi E1 with 1 set of sheeter rollers		
Combi E2 with 2 sets of sheeter rollers		

DIMENSIONS		WEIGHT	CONNECTED LOAD
Lenght	3911 mm	nett 570 kg	230/400 V, 50 Hz + earth
Width	773 mm	gross...600.kg	1,5 kVA
Height	1465 mm		

OPTIONS

- Hopper instead infeed conveyor
- Mechanical flour duster
- Flour duster with own drive
- Driven top band instead pressure board
- Pressure board for pointed ends
- Inclined frame
- Customer specific Blue Box

WP HATON BV

Industrieterrein 13 // 5981 NK Panningen // Netherlands // Phone +31 77307-1860 // Fax +31 77307-5148 // info@wp-haton.com // www.wp-haton.com



COMBI E

Long Moulder

COMBI E

Picture Combi E

SUITABLE FOR WHEAT, WHEAT/RYE DOUGHS
(UP TO 60% RYE) DOUGHS.



BENEFITS

- Precise centering of dough pieces before sheeting/ long moulding
- Accurate sheeting perfectly tailored to different types of dough
- Easy cleaning and access
- No sticking and skidding of dough pieces
- Easy hinged pressure board, easy cleaning
- Simple readout of all adjustments for repeatability
- Possibility to process many types of dough
- Modern design
- Compact machine

BASIC EXECUTION:

- Infeed conveyor with adjustable side guides
- Cover plates stainless steel
- Moulding bridge glass bead blasted
- Synthetic rollers
- Stainless steel curling net
- Hinged pressure board, adjustable in height with adjustable side guides
- Teflon coated side guides

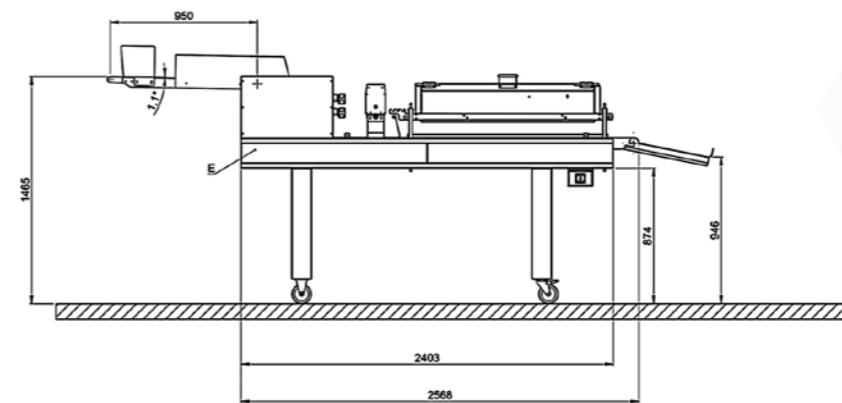
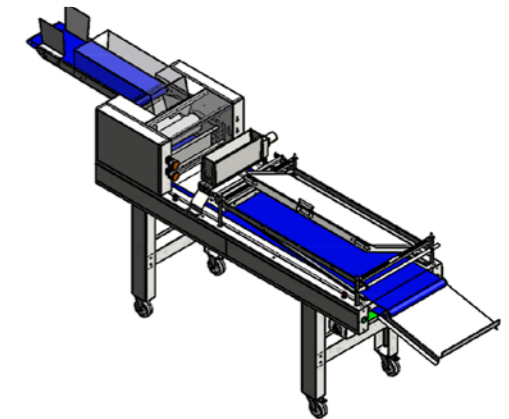
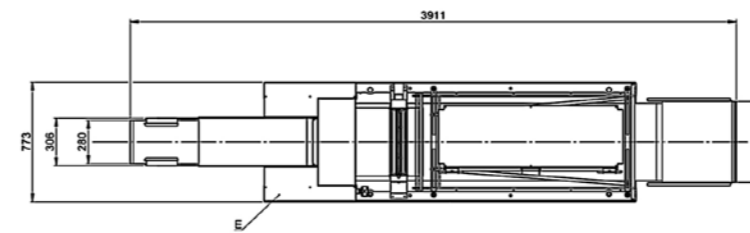

Illustration Combi E1 with infeed conveyor and sheeter head