

## CR 59 AT

TYPE	WEIGHT RANGE	CAPACITY
CR 59 AT	90 - 1600 gr	up to 2500 pcs/h., E-motor 1,1 kW, 1400 rpm, n cone 27 rpm
		2500 up to 3600 pcs/h., E-motor 1,1 kW, 1400 rpm, n cone 39 rpm
		3600 up to 5000 pcs/h., E-motor 1,1 kW 1400 rpm, n cone 57 rpm

DIMENSIONS		WEIGHT	CONNECTED LOAD
Length	1180 mm	nett 375 kg	230/400 V 3 ph 50 Hz + earth
Width	1270 mm	gross 425 kg	1,1 KVA, with oiling 4 KVA
Height	1604 mm	Shipping volume 2.4 m <sup>3</sup>	

### OPTIONS

#### CR 59 AT without oil

- Infeed conveyor
- Discharge conveyor with discharge cone
- Heating with fan
- Frequency inverter for variable cone speed
- Flour duster
- Flour duster with independent drive (only in combination with discharge conveyor)
- Customer specific Blue Box

#### CR 59 AT with oil

- Infeed conveyor
- Discharge conveyor with discharge cone
- Frequency inverter for variable cone speed
- Oil on discharge conveyor divider
- Oil on infeed conveyor rounder
- Signalisation oiling
- Customer specific Blue Box

#### WP HATON BV

Industrieterrein 13 // 5981 NK Panningen // Netherlands // Phone +31 77307-1860 // Fax +31 77307-5148 // info@wp-haton.com // www.wp-haton.com



# CR 59 AT

## Conical Rounder

# CR 59 AT

Picture CR 59 AT

SUITABLE FOR MANY COMMON DOUGH TYPES, SUCH AS WHEAT, WHEAT/RYE, MULTIGRAIN AND WHOLE WHEAT DOUGHS. THE DOUGH PIECES ARE TAKEN OVER BY THE ROTATING CONE AND SHAPED INTO ROUND DOUGH PIECES BY THE SPECIALLY ADJUSTABLE SHAPED TRACKS. BECAUSE THE TRACKS ARE MECHANICALLY PROCESSED, THERE IS A VERY HIGH PRECISION BETWEEN TRACKS AND CONE.



## BENEFITS

- Excellent round moulding results
- Perfect separation between dough pieces coming from the divider
- Minimum of dough crumbs
- Perfect transfer from dough pieces on the out-feed side
- Adjustable tracks
- Wide weight range
- Cone speed adjustable (option)
- Easy handling of doughs with a high water absorption
- No flour necessary in order to avoid sticking of dough pieces on cone and tracks

## BASIC EXECUTION:

### Without oil

- Cast iron cone, Teflon coated
- Aluminium tracks, in- and outside Teflon coated
- Adjustable tracks movable on platform
- Cone with top bearing
- Cover plates stainless steel, brushed
- Undercarriage nickel steel with 4 castors, dowel pins and blocking
- With operation control panel

### With oil

- Cast iron cone, Teflon coated
- Aluminium tracks, in- and outside Teflon coated
- Adjustable tracks movable on platform
- Cone with top bearing
- Cover plates stainless steel, brushed
- Undercarriage nickel steel with 4 castors, dowel pins and blocking
- With operation control panel
- Oil spraying on cone
- Heating with fan

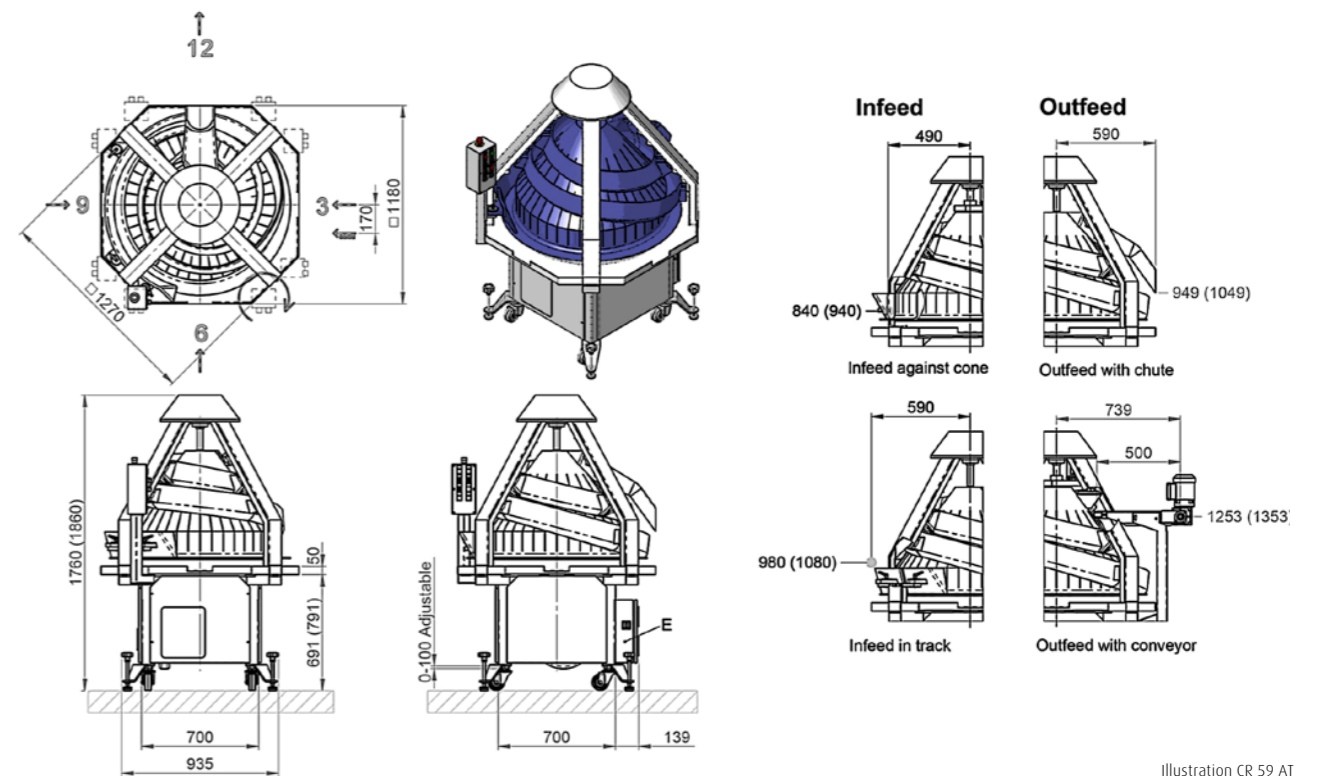

Illustration CR 59 AT