

V 900

TYPE	PARTITIONS	WEIGHT RANGE	CAPACITY
V 900-3	25 mm	300 - 1800 gr	1500 - 4500 pcs/h.
V 900-4	25 mm	200 - 1300 gr	2000 - 6000 pcs/h.
V 900-5	25 mm	200 - 980 gr	2500 - 7500 pcs/h.
V 900-5-5	12,5 mm	200 - 1100 gr	2500 - 7500 pcs/h.
V 900-6	12,5 mm	150 - 890 gr	3000 - 9000 pcs/h.
V 900-7	12,5 mm	150 - 740 gr	3500 - 10500 pcs/h.
V 900-8	12,5 mm	150 - 630 gr	4000 - 12000 pcs/h.
V 900-3/6	12,5 mm	300 - 1925 gr	1500 - 4500 pcs/h.
		150 - 890 gr	3000 - 9000 pcs/h.
V 900-4/8	12,5 mm	200 - 1400 gr	2000 - 6000 pcs/h.
		150 - 630 gr	4000 - 12000 pcs/h.

DIMENSIONS		WEIGHT	CONNECTED LOAD
Length	2401 mm	nett 2900 kg	230/400 V 3 ph 50 Hz + earth
Width	1964 mm	gross kg	7,5 KVA
Height	1796 mm		

OPTIONS

- Hopper inside HDPE material
- Oiling of hopper
- Discharge conveyor length variable
- Flour duster
- Belts, felt
- Hopper inside Teflon coated 150 ltr.
- Connection for Checkweigher
- Oil catch pan with trolley
- Secondary oiling system for sugar dissolving oil
- Allen Bradley controls
- Customer specific Blue Box

WP HATON BV

Industrieterrein 13 // 5981 NK Panningen // Netherlands // Phone +31 77307-1860 // Fax +31 77307-5148 // info@wp-haton.com // www.wp-haton.com



V 900
Dough Divider

V 900

Picture V 900 with oil catch pan on rack

DESIGNED FOR HIGH SPEED DOUGH MAKE UP LINES. CAN BE USED FOR VARIOUS PROCESSES AND CAN BE INTEGRATED IN MOST CLASSIC BREAD LINES. THE V 900 IS SUITABLE TO DIVIDE ALL COMMON DOUGHS SUCH AS WHEAT, RYE, MULTIGRAIN, WHOLE WHEAT, HIGH WATER ABSORPTION DOUGHS, AS WELL AS STIFF DOUGHS.



BENEFITS

- High weight accuracy over a long period by using the best possible parts and materials
- Heavy duty drive mechanism with a combination cam disc and crankshaft drive
- Long machine life with minimum down time and a high weight accuracy
- Excellent processing of all common doughs – straight doughs as well as fermented doughs
- Dough is portioned in a stand still position of the measuring pistons, under adjustable hydraulic pressure in order to guarantee a high compression and an equal filling of all pistons
- Automatic cleaning system with secondary oil pump using sugar dissolving oil (option)
- Discharge conveyor easily removable for cleaning by using a special trolley (option)
- Heavy duty dividing mechanism with a division box made out of Ni-Resist (high wear alloy)
- Easy cleaning of in- and outside conveyors, hopper can be disconnected for easy cleaning
- Large weight range
- Open front lever design for visual control of dough discharge
- Oil catch pan underneath complete machine
- All settings of the V 900 can be done automatically and stored in the PLC
- Touch screen operation with service program

BASIC EXECUTION:

- Number of pistons 3-4-5-6-7-8 and 3/6 – 4/8
- Dividing unit Ni-Resist with automatic oiling system with 12 adjustable dosing valves
- Automatic belt oiling system
- Discharge conveyor 500 mm with belt tensioner, scraper and catch tray
- Separate drive on inner – and out-feed conveyor with drum motor inclusive frequency inverter
- Pneumatic discharge flap with plastic scraper
- Hopper stainless steel inside Teflon coated contents 75 ltr.
- Hopper base Teflon coated
- Frequency inverter for variable speed of drive system
- Operation by touch screen with settings for all adjustments and recipe control
- Main piston Ni-Resist
- Measuring pistons bronze
- Knife hardened steel
- Cover plates stainless steel, brushed, and equipped with safety switches
- Frame steel nickel coated
- Crankshaft and drive rods cast iron nickel plated

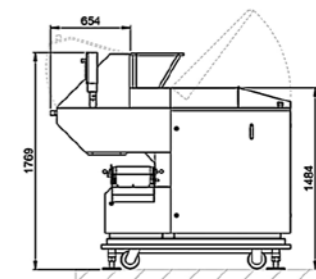
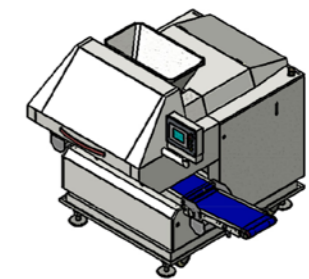
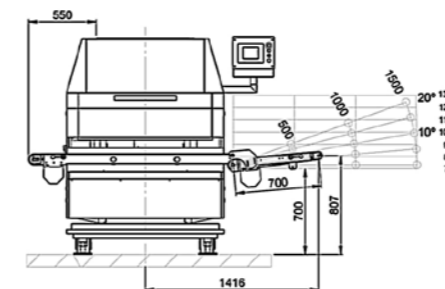
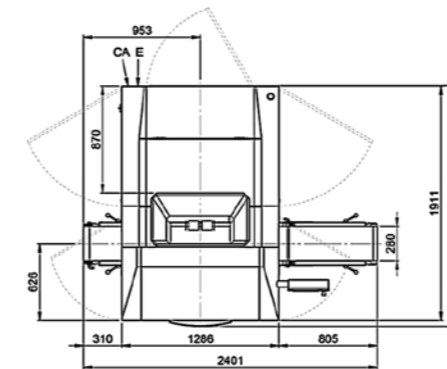

Illustration V 900