



160
200
300

INDUSTRIAL REMOVABLE BOWL BEATER ARMS MIXER

Top quality dough

Reliable and
practical hydraulics
system

Increased
productivity

The most important objective of Mixer staff in the design and manufacture of beater arms mixers is quality doughs.

For this reason, special care has been taken with the joint fits between fork tool and blade arm and with finding the optimal ratio of bowl speed to tool speed. Beater arms mixers generally work at higher speeds to give a more refined and accurate processing, which contributes to improved quality of end products. Smaller quantities of dough can also be processed, from around 10% of total capacity and above.

Higher speeds require redimensioned parts and components and a lot of work of Mixer went into producing a series of robust and reliable pieces of equipment.

IBTE LINE

IBTE beater arms mixers with removable bowls are flexible both in terms of use and productivity for artisans working with delicate doughs for confectionery and more tenacious kneadings for bread and pizza.

IBTE mixers have the advantage of a removable bowl trolley which allows for easy and safe transfer of large quantities of dough to give efficient management during processing, when adding ingredients and when leaving dough to rise.

PRACTICAL AND RELIABLE HYDRAULICS SYSTEM

IBTE mixers have been equipped with a hydraulic circuit to lift the arm support unit and trolley hook to improve efficiency and make unhooking the trolley more practical as well as simplifying maintenance operations.

OPTIONAL Amongst other options IBTE models can also be produced with stainless steel structure.



IBT.E 160-200-300 REMOVABLE BOWL BEATER ARMS MIXER TECHNICAL FEATURES

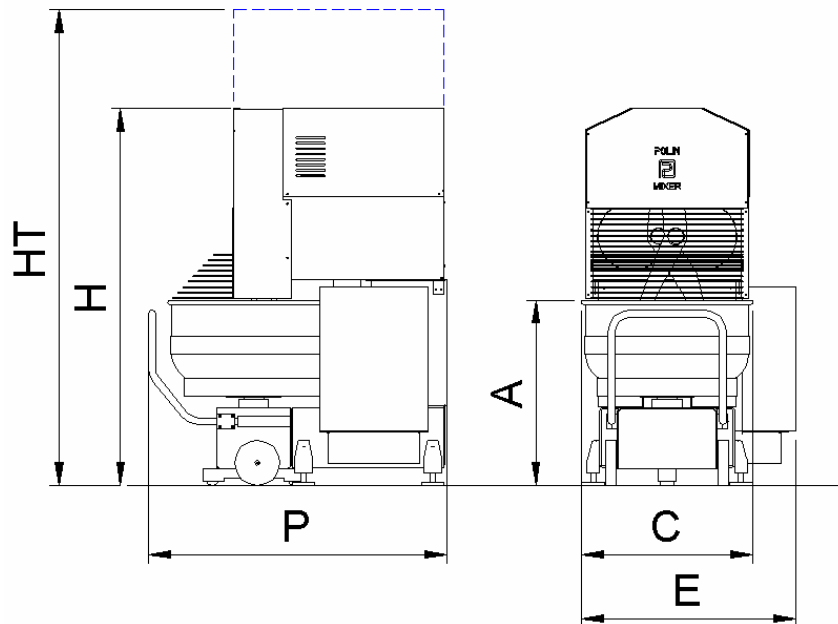

TECHNICAL DATA

Model		IBT.E/160	IBT.E/200	IBT.E/300
Dough capacity (min./max) *	kg	20/160	20/200	30/300
Flour capacity (min./max) *	kg	12/100	12/125	18/180
Water capacity (min./max) *	lt	8/60	8/75	12/120
Bowl volume	lt	280	330	470
% Water/flour minimum	%	55	55	55
Arm turns 1st speed (50/60hz)	rpm	37	37	37
Arm turns 2nd speed (50/60hz)	rpm	57	57	57
Bowl turns 1st speed (50/60hz)	rpm	6	6	6
Bowl turns 2nd speed (50/60hz)	rpm	9	9	9
Motor power 1st speed	kw	8.1	8.1	10.3
Motor power 2nd speed	kw	10.3	10.3	13.4
Input current V. 230	A	38	38	48
Input current V. 400	A	22	22	27
Height from bowl lip	A mm	980	1030	1050
Total length	P mm	1650	1660	1870
Bowl width	C mm	955	955	1155
Total width	E mm	1200	1200	1360
Total height	H mm	2090	2090	2120
Total height with opened guard	HT mm	2640	2640	2640
Net weight	kg	2010	2030	2210

*: capacity determined in view of % liquid/flour equal to 60

SUPPLIED STANDARD EQUIPMENT

Bowl, arms and bowl guard made of AISI 304 stainless steel	Head lifting/descent and release/connection of the trolley through oil-pressure cylinders
Structure made of grey RAL 9007 coated steel, raised from ground on stainless steel feet	Overvoltage and overload motor protection
Movement transmission to the arms through V belts and oil bath reduction gear, to the bowl through friction wheel	Tension 400 V - frequency 50 Hz - 3 phases
Trolley with bowl assembled on wheels	Four meters of cable with CEE plug
	Operating/Maintenance instructions and CE statement of Compliance
	Pallet packaging with nylon

CONTROL PANEL

Two timers setting the working time with automatic shift from 1st to 2nd speed	Push button for head lifting/release of trolley with the presence of the operator
Push button for machine head lifting/descent consent	1st speed start push button
Push button for head descent/connection of trolley with presence of the operator	2nd speed start push button
Mushroom headed Emergency stop push button	Stop push button

OPTIONAL EXTRA EQUIPMENT

Stainless steel structure	Special voltage/Frequency: 230/50/3 220/60/3 380/60/3
Extra-bowl carrying trolley	Wooden crate